

OA825 Series

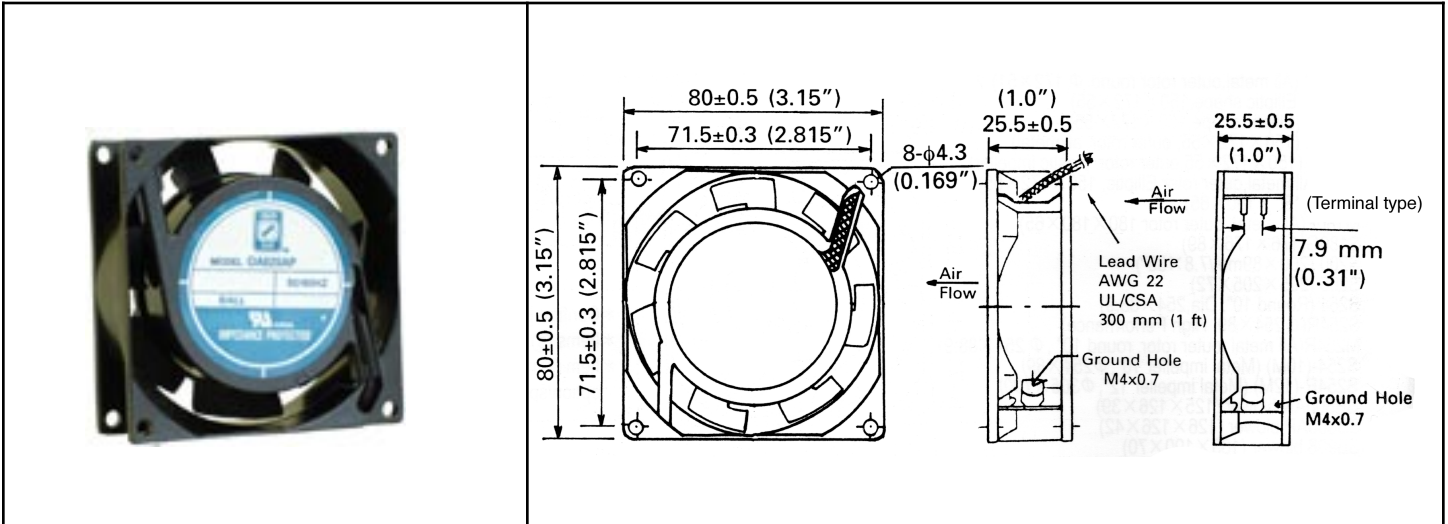

80 x 25mm
(3.15" x 1.0")



Frame	Diecast Aluminum	<u>Operating Temperature</u> Ball Bearing -20C ~ +80C Sleeve Bearing -10C ~ +50C	
Impeller	PBT, UL94V-O plastic		
Connection	2x Lead Wires 22 AWG or terminals		
Motor	Shaded pole, impedance and thermally protected	<u>Life Expectancy</u> Ball Bearing 60,000 hours (L10 at 40C) Sleeve Bearing 30,000 hours (L10 at 40C)	
Bearing System	Dual ball or Sleeve	<u>Dual Voltage</u> Connection via 4x leads. Fans can be configured for 115V or 230V operation.	
Insulation Resistance	>100M ohm between lead-wire and frame (500VDC)		
Dielectric Strength	1 min at 1500 VAC, 50/60Hz		

Model Number	Speed (RPM)	Airflow (CFM)	Noise (dB)	Volts AC	Voltage Range	Watts	Max. Static Pressure ("H2O)
OA825AP-11-1*	3000	25	28	115	80~130	9	.21
OA825AP-11-2*	2300	18	24	115	80~130	6	.14
OA825AP-11-3*	1600	13	20	115	80~130	4	.11
OA825AP-22-1*	3000	25	28	230	160~260	9	.21
OA825AP-22-2*	2300	18	24	230	160~260	6	.14
OA825AP-22-3*	1600	13	20	230	160~260	4	.11
OA825AP-11/22-1W**	3000	25	28	115/230	80~260	9	.21
OA825AP-11/22-2W**	2300	18	24	115/230	80~260	6	.14
OA825AP-11/22-3W**	1600	13	20	115/230	80~260	4	.11

* Indicate "TB" (Terminal Ball Bearing), "WB" (12" Wire Leads, Ball Bearing), "TS" (Terminal, Sleeve Bearing), "WS" (12" Wire Leads, Sleeve Bearing)
 ** Indicate "B" (Ball Bearing) or "S" (Sleeve Bearing)